

Cambridge Electronic Design Limited

Fitting a 2501-9 Spike2 top box to a micro1401 mk 1

Introduction

The micro1401 is designed so that it can be fitted with a variety of add-on units available from CED. The add-on units are called 'top boxes' and are mechanically similar to the main unit. Each micro1401 may have up to two top boxes fitted to it. This leaflet describes how to fit a 2501-9 Spike2 top box to an unexpanded unit.

Before commencing the work, please read the instructions carefully and arrange a clear working space onto which you can lay out the pieces. Ensure that both you and the micro1401 are earthed, to prevent the risk of electrostatic discharge. Ideally, the micro1401 should be connected to mains earth and you should be connected to the micro1401 by a wrist strap. If you are in any doubt about being able to carry out the dismantling and reassembly, please ask a qualified engineer or send the micro1401 to the CED Service Department. CED will make a small charge for this service.

It is strongly recommended that you re-check each step after you have completed it, as it is more difficult to correct errors later.

The fitting kit

The fitting kit comprises:

- | | | | |
|--------------------------|-----------------------------------|--------------------------|----------------------|
| <input type="checkbox"/> | Spike2 card & inner can | <input type="checkbox"/> | 26-way riser card |
| <input type="checkbox"/> | Spike2 outer case | <input type="checkbox"/> | 50-way riser card |
| <input type="checkbox"/> | Slotted inner can lid | <input type="checkbox"/> | Digital input cable |
| <input type="checkbox"/> | 2 off stacking bars | <input type="checkbox"/> | Digital output cable |
| <input type="checkbox"/> | 2mm hex wrench | <input type="checkbox"/> | Earthing strap |
| <input type="checkbox"/> | Monitor ROM upgrade (if required) | <input type="checkbox"/> | Set of screws |

Fitting the top box

1. Switch off the micro1401 and remove all cables connected to it.
2. Place the micro1401 on a clear bench with the rear facing you and spread out the contents of the top box kit in front of you.
3. Undo the four countersunk screws from the rear panel of the micro1401, and remove it. Earlier models use 1-pt crosshead fixings, later ones 2mm hex fixings. Lay the panel to one side of the micro1401.
4. Slide out the black top panel from the outer case.
5. Fasten the two bright-metal stacker bars to the tops the micro1401 side panels using six 10mm M3 pan head screws. Do not use washers. The stacker bars are asymmetric and fit with the holes away from the outer edge of the side panel, and the recesses upward.
6. Slide the bright-metal inner can out and remove the earth lead from the left hand side. Note the order of the washer and eyelet; this is important for its EMC performance. Unscrew the six screws along the sides. If your unit has separate shakeproof washers, take care not to drop any of them inside. Later models use fixings with integral shakeproof washers. Lift off the lid. This lid will not be used again so it can be discarded.

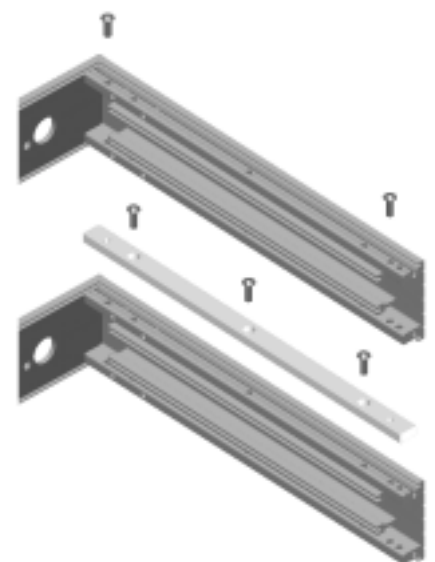

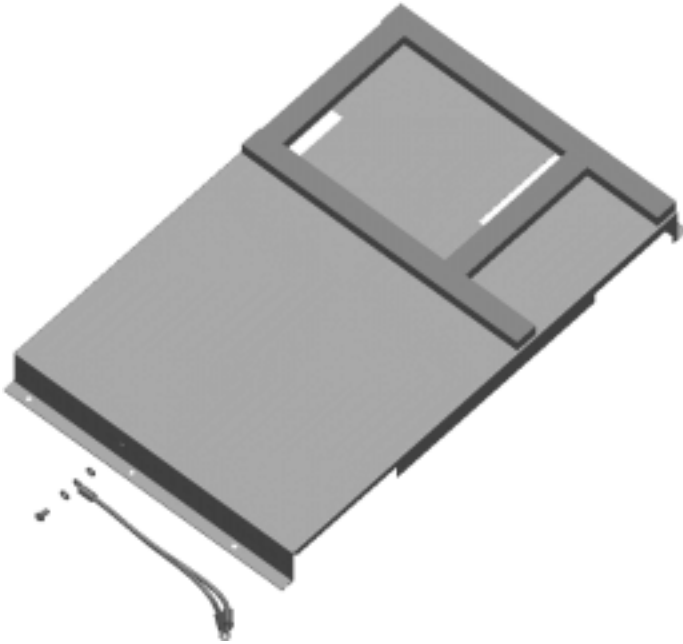

7. Replace the micro1401 monitor ROM if a newer version has been supplied. We will not send you one if our records show your unit is up to date. The monitor ROM is located near the elevated card on the main board in the socket marked ROM0 (IC20). Carefully remove it with a small flat blade screwdriver placed between the ROM and the socket underneath. Fit the new ROM in exactly the same orientation, i.e. with the DOT on the label nearest to the micro1401 front panel.
8. Fit the new inner can lid provided, with slots, to the micro1401 inner can base. The edge with the mesh covered foam goes to the front of the unit. Be sure to refit all screws and washers. The earth cable has a washer between the eyelet and the inner lid. Slide the can assembly back.
9. Remove the rear panel of the Spike2 outer case by unscrewing the four countersunk screws. Place the rear panel to one side.
10. Place the Spike2 top box outer case on top of the micro1401 so that its front panel is directly above the micro1401 front panel. It is now possible to fasten the Spike2 case to the stacker bars fitted in step 5 above, using a 10mm M3 pan head screw in each corner.
11. Reattach the rear panel to the micro1401 (lower case) with the four countersunk screws. Do not tighten yet. The panel will hold the sides together while you perform step 13 below.
12. Remove the lid of the bright-metal inner can of the Spike2 by unscrewing the six screws along the sides. Lay to one side for the moment.
13. Carefully slide the Spike2 base into the lower pair of slots on the Spike2 outer case until it is fully inserted. Take care, because the foam strips underneath will be squeezed between the two cans.
14. Observe the Spike2 top box from above and locate the two slots that allow connection through to the micro1401 below. These connections will be made by the two riser cards provided with the kit. The smaller one (26-way) locates in the slot next to the front panel BNC connectors with its flying cable pointing towards the rear. The larger one (50-way) locates in the slot near the side panel with its flying cable pointing towards the front.
15. Carefully lower the two riser cards through the slots and into the mating connectors on the micro1401 board. You must ensure that they are aligned exactly with the mating connectors BEFORE gently pushing them home.
16. Connect the flying cable on each riser card into the adjacent connectors on the Spike2 top box board. As you do this, the riser card may move slightly, but this is acceptable.
17. Replace the top box lid, removed in step 12, and secure it with six 10mm M3 pan head screws (with integral washers).

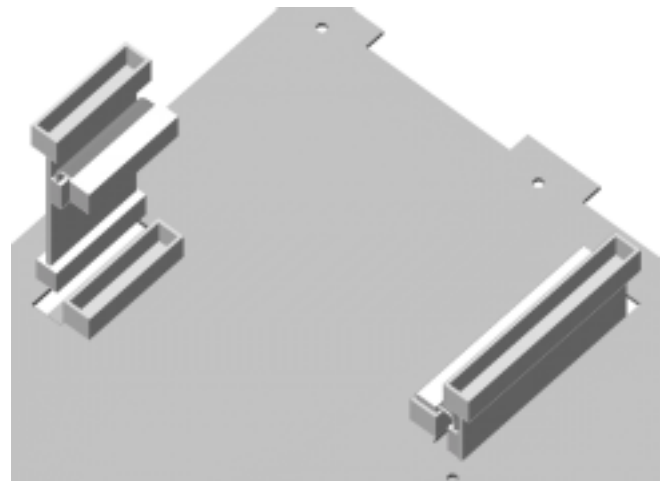

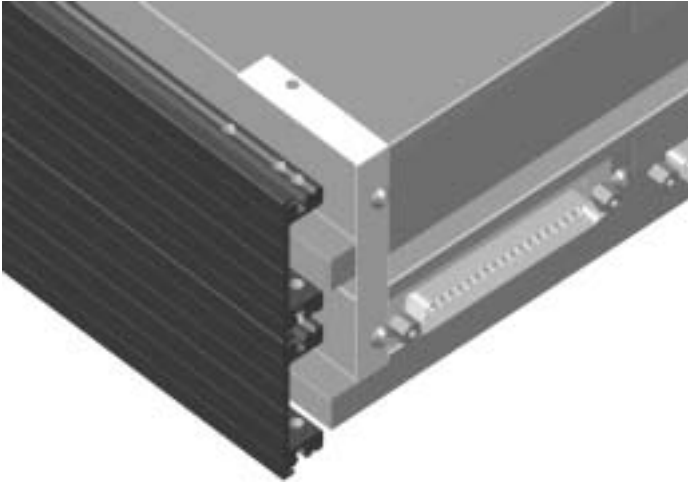

18. Connect the earthing strap between the two inner cans. To do this you must undo the pan head screw on the left-hand side of the micro1401 host connector, locate it in one end hole of the earth strap and secure the screw and earthing strap assembly back in the host connector. Do not fully tighten yet.
19. Secure the middle hole of the earthing strap to the Spike2 inner can with a 5mm M3 pan head screw with shakeproof washer in the hole provided. Tighten both screws and, in the interest of personal safety, bend the unused section of earthing strap over the top of the inner can. This unused section is required if a second top box is fitted.
20. Secure the micro1401 rear panel by tightening the four black countersunk screws.
21. Slide the black top plate (removed in step 4) into the uppermost slot of the Spike2 outer case.
22. Fit the rear panel onto the top box and secure it with four black countersunk screws. Note that the recessed hole on the inside of the panel goes on the left-hand side.
23. Fit and secure the digital input cable to the digital input plug on the micro1401 and to the plug on the Spike2 top box directly above it.
24. Similarly fit and secure the digital output cable between the output sockets. The assembly procedure is now complete.

Self test

Connect only the power cable to the micro1401 and switch on. At the end of its power-up self test, the micro1401 red test LED should go out indicating that all is well and the unit is ready for use. If the red test LED flashes, this indicates an error. If this happens you should check each step for mistakes. Contact the CED service department if the problem persists.