

# Cambridge Electronic Design Limited

---

## Fitting a 2501-3 ADC12 Top Box to an expanded micro1401 mk 1

### Introduction

The micro1401 is designed so that it can be fitted with a variety of add-on units available from CED. The add-on units are called 'top boxes' and are mechanically similar to the main unit. Each micro1401 may have up to two top boxes fitted to it. This leaflet describes how to fit a 2501-3 ADC12 top box to a unit that already has one top box.

Before commencing the work, please read the instructions carefully and arrange a clear working space onto which you can lay out the pieces. Ensure that both you and the micro1401 are earthed, to prevent the risk of electrostatic discharge. Ideally, the micro1401 should be connected to mains earth and you should be connected to the micro1401 by a wrist strap. If you are in any doubt about being able to carry out the dismantling and reassembly, please ask a qualified engineer or send the micro1401 to the CED Service Department. CED will make a small charge for this service.

It is strongly recommended that you re-check each step after you have completed it, as it is more difficult to correct errors later.

### The fitting kit

Enclosed is a fitting kit comprising:

- |                          |                        |                          |                   |
|--------------------------|------------------------|--------------------------|-------------------|
| <input type="checkbox"/> | ADC12 card & inner can | <input type="checkbox"/> | 26-way riser card |
| <input type="checkbox"/> | ADC12 outer case       | <input type="checkbox"/> | 50-way riser card |
| <input type="checkbox"/> | 2 off stacking bars    | <input type="checkbox"/> | Set of screws     |
| <input type="checkbox"/> | 2mm hex wrench         |                          |                   |

### Fitting instructions

1. Switch off the micro1401 and remove all cables connected to it.
2. Place the micro1401 on a clear bench with the rear facing you and spread out the contents of the top box kit in front of you.
3. Undo the four countersunk screws from the upper rear panel of the micro1401, and remove it. Earlier models use 1-pt crosshead fixings, later ones 2mm hex fixings. Lay the panel to one side of the micro1401.
4. Slide the black top panel from the outer case.
5. Fasten the two bright-metal stacker bars to the tops the micro1401 side panels using six 10mm M3 pan head screws. Do not use washers. The stacker bars are asymmetric and fit with the holes away from the outer edge of the side panel, and the recesses upward.
6. Observe the folded-over earthing strap at the left-hand rear of the unit. Straighten this out. Unscrew the six screws along the sides of the exposed top-box inner can. If your unit has separate shakeproof washers, take care not to drop any of them inside. Later models use fixings with integral shakeproof washers. Lift off the lid. This lid will be reused as part of the ADC12 top box at step 15.

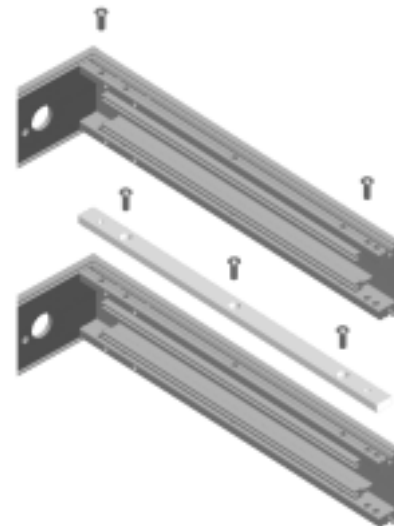
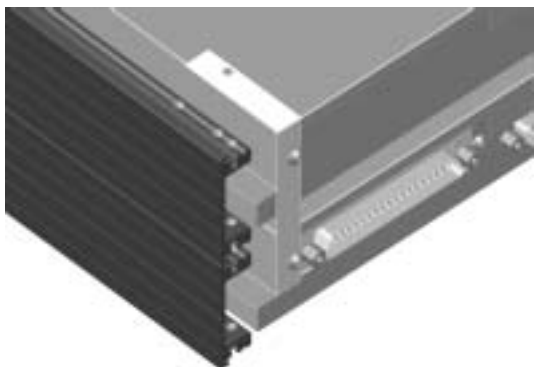

7. Remove the lid of the bright-metal inner can of the ADC12 by unscrewing the six screws along the sides. Fit it to the existing top box. The edge with the mesh-covered foam goes to the front of the unit. Ensure that the tops of both the riser cards, that are already present in the existing top box, are visible though the slots in the new cover. Be sure to refit all screws and washers. In the interest of personal safety, you should bend the top of the earthing strap over the top of the new cover.
8. Remove the rear panel of the ADC12 outer case by unscrewing the four countersunk screws. Place the rear panel to one side.

9. Place the ADC12 top box outer case on top of the micro1401 so that its front panel is directly above the micro1401 front panel. It is now possible to fasten the ADC12 case to the stacker bars fitted in step 5 above using a 10mm M3 pan head screw in each corner.
10. Reattach the rear panel to the middle box with the four countersunk screws. Do not tighten yet. The panel will hold the sides together while you perform step 11 below.

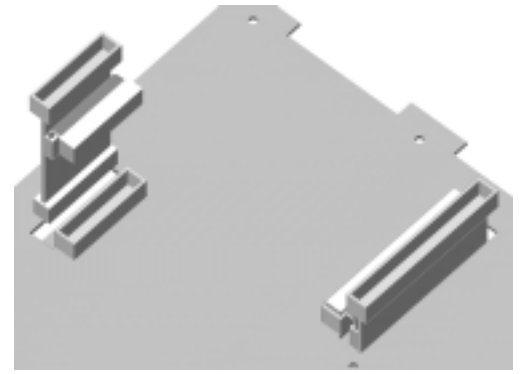

11. The earthing strap will now have to be bent outwards through 180° to allow the following step to proceed: carefully slide the ADC12 base into the lower pair of slots on the ADC12 outer case until it is fully inserted. Take care, because the foam strips underneath will be squeezed between the two cans. Ensure that the earthing strap is not bent under the base.
12. Observe the ADC12 top box from above and locate the two slots that allow connection through to the top box below. These connections will be made by the two riser cards provided with the kit. The smaller one (26-way) locates in the slot next to the front panel BNC connectors with its flying cable pointing towards the rear. The larger one (50-way) locates in the slot near the side panel with its flying cable pointing towards the front (see diagram D).
13. Carefully lower the two riser cards through the slots and into the mating connectors just below the board. You must ensure that they are aligned exactly with the mating connectors BEFORE gently pushing them home.
14. Connect the flying cable on each riser card into the adjacent connectors on the ADC12 top box board. As you do this, the riser card may move slightly, but this is acceptable.
15. Fit the bright-metal lid, removed from the micro1401 in step 6, to the ADC12 base and secure it with six 10mm M3 pan head screws (with integral washers).
16. Secure the top hole of the earthing strap to the ADC12 inner can with a 5mm M3 pan head screw and shakeproof washer, in the hole provided.
17. Slide the black top plate (removed in step 4) into the uppermost slot of the ADC12 box outer case.
18. Fit the rear panel onto the top box and secure with four black countersunk screws. The recess on the inside of the panel goes to the left-hand side. The assembly procedure is now complete.

### **Self test**

Connect only the power cable to the micro1401 and switch on. At the end of its power up self test, the micro1401 red test LED should go out indicating that all is well and the unit is ready for use. If the red test LED flashes, this indicates an error. If this happens you should re-check steps 1 to 18 for mistakes. Contact the CED service department if the problem persists.