

Cambridge Electronic Design Limited

Fitting a 2701-5 Signal top card to a Power1401

Introduction

The CED Power1401 (hereafter the '1401') is designed so that it can be fitted with a variety of add-on cards available from CED. These 'top cards' are housed in an extended version of the case hardware. Each 1401 may have several top cards fitted to it, depending on the chassis metalwork. This leaflet describes how to fit a 2701-05 Signal top card to an unexpanded 1401.

Before commencing the work, please read the instructions carefully and arrange a clear working space onto which you can lay the pieces out. Ensure that both you and the 1401 are earthed, to prevent the risk of electrostatic discharge. Ideally, the 1401 should be connected to mains earth and you should be connected to the 1401 by a wrist strap. If you are in any doubt about being able to carry out the dismantling and reassembly, please ask a qualified engineer or send the 1401 to the CED Service Department. CED will make a small charge for this service.

It is strongly recommended that you re-check each step after you have completed it, as it is more difficult to correct errors later.

The fitting kit

The fitting kit comprises:

<input type="checkbox"/>	Signal card (2701-05)	<input type="checkbox"/>	26-way ribbon cable
<input type="checkbox"/>	Dual-height inner can (lid & base)	<input type="checkbox"/>	50-way ribbon cable (2 off)
<input type="checkbox"/>	Signal outer case (front, sides & back)	<input type="checkbox"/>	60-way digital I/O ribbon cable
<input type="checkbox"/>	8 off hex spacer pillars	<input type="checkbox"/>	Multiplexer coaxial cable
<input type="checkbox"/>	2 off stacking bars	<input type="checkbox"/>	Internal power cable
<input type="checkbox"/>	60-way pin header	<input type="checkbox"/>	6 off 10mm M3 pan head screws
<input type="checkbox"/>	Coaxial cable with free-wire end (2 off)	<input type="checkbox"/>	4 off 12mm M3 pan head screws
<input type="checkbox"/>	2mm hex wrench		

The procedure

A digital I/O pin header is soldered onto the 1401 base card (the 'motherboard'). Two coaxial cables are soldered to unoccupied positions on the motherboard. The Signal card is bolted onto the motherboard with pillars, and cables are fitted between them. This assembly is housed in a dual-height inner can. The outer case is extended by adding new sections to form a dual-height outer case. All the fixings are reused, so they should be saved. All the original outer-case metalwork is reused. You may save the original inner-can metalwork if you envisage ever converting back to an unexpanded unit.

Dismantling the old 1401

1. Switch off the 1401 and remove all cables connected to it. Position it on the bench with the back towards you.
 2. Undo the four countersunk screws from the rear panel of the 1401, and remove it. We provide a 2mm hex wrench for this. There is no need to disconnect the green & yellow earth wire.
 3. Slide the black top panel from the outer case.
 4. The inner can is now exposed. Slide it out of the case until the spade connector protruding from the left-hand side is accessible. Be careful not to splay the case sides. Disconnect the spade tag (it may be quite tight) and slide the can out completely. NB: All descriptions of left and right are as seen from the back of the unit.
 5. Unscrew the six 5mm M3 screws along the sides of the inner can. These are special screws with integral shakeproof washers ('combo screws'). Lift the lid away.
 6. The 1401 motherboard is now visible. Note the two graphite-impregnated gasket strips at either side. Save these carefully; they are quite delicate. Observing electrostatic precautions, unclip the DRAM module from its slanting socket by pushing apart the white extraction levers. Store the DRAM carefully, preferably in an anti-static bag.
 7. The motherboard is secured by ten 5mm M3 combo screws on the card itself and ten hex bolts ('screwlocks') that anchor the D-type connectors to the rear fold. Observing electrostatic precautions, undo all these fixings. (A 6BA or a 440UNC nut spinner is the best tool for the screwlocks and also, later on, for the hex pillars.)
 8. Remove the motherboard by lifting the back edge first, then sliding the front-panel BNC connectors out of the front fold. It is quite likely the shells may fall off some of the rear-panel D-type connectors; do not worry, they are easily replaced during reassembly.
-

Building the new inner can

1. Solder the 60-way pin header into its position at the back of the motherboard. Make sure it is fully inserted and level before soldering (see diagram below). Deflux the joints afterwards.
2. On the motherboard, locate the unoccupied resistor-pack positions marked 'RP24' and 'RP25' (see diagram below). They are behind the dense block of circuitry behind the rear analogue connector. Solder the central wire of one of the free-ended coax cables into the hole marked 'A', and the braid into 'B'. This becomes the cable to DAC 6. Solder the central wire of the other free-ended coax into 'C', and its braid into 'D'. This becomes the cable to DAC 7. Deflux the joints.

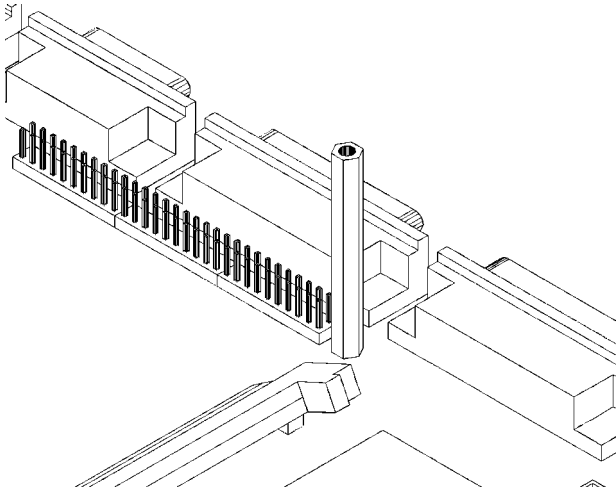

60-way pin header *in situ*

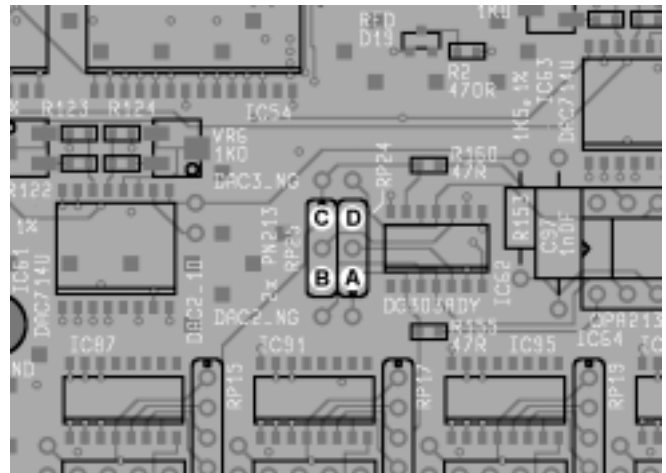

Attachment points for coax cables

3. Offer the motherboard to the dual-height inner can base. First feed the BNCs through their holes, then make sure that all the LEDs line up with their holes. If any have been bent, they may gently be pushed back into position. Make sure the D-type shells are all in place, longer side uppermost, before lowering the back edge past the rear fold.
4. Replace the ten screwlocks on the D-type connectors but do not tighten them fully.
5. The fixing point beneath the DRAM and the one next to the rear-panel switch are secured by two of the 5mm M3 combo screws removed previously. The remaining eight fixing points are occupied by the spacer pillars. Screw them all down loosely at first, then tighten them fully. Lastly tighten the screwlocks.
6. Observing electrostatic precautions, replace the DRAM.
7. Connect the two 50-way ribbon cables to the two headers next to the pillar near the middle of the board, and the 26-way cable to the header by the right edge. These cables are positioned with the free ends hanging to the left and the red edges towards the front of the unit. Connect the 40-way digital I/O ribbon cable to the pin header at the back of the motherboard. The red edge goes on the left and the cable points forwards.
8. Plug the multiplexer coaxial cable (which has plugs at both ends) into the receptacle to the front of the two 50-way headers. Plug the internal power cable into the socket behind the rear-panel switch.
9. Still observing electrostatic precautions, position the Signal top card on the pillars. Feed the multiplexer coaxial cable through the small square hole before you position the card. Once the card is in position feed the 50-way ribbon cables through their slots, for instance by nudging them with a pencil. Nudge the DAC6 & DAC7 cables through the slot nearer the front.
10. When the LEDs are all safely through their holes, screw the top card down with the remaining eight 5mm M3 combo screws.
11. Mate the three ribbon cables with their connectors. Plug the analogue coaxial cable into either of the two receptacles marked 'ANALOGUE MUX NODE'. Plug the DAC6 & DAC7 cables into the receptacles marked 'DAC6 in' and 'DAC7 in', respectively. Plug the internal power cable into the nearer of the two sockets.
12. Position the graphite gaskets on the motherboard. Note that they are asymmetric, and fit with the holes closer to the inside and offset to the front.
13. Fit the dual-height inner lid. Position the front lip first, then manoeuvre the back lip over the rear fold of the base. There is a retaining gusset behind the lip, and the rear fold fits in the gap in between.
14. Ensure that the graphite gaskets are properly lined up, e.g. by centring the holes with a pencil tip, and screw down the inner can lid with the six 5mm M3 combo screws removed previously.

Fitting a 2701-5 Signal top card to a Power1401

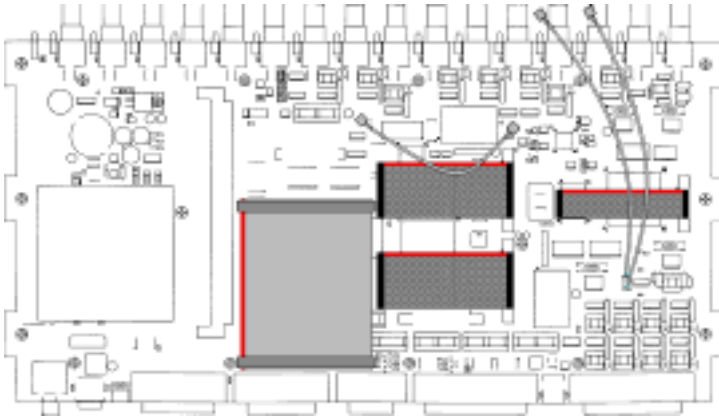

Expansion cables on the motherboard

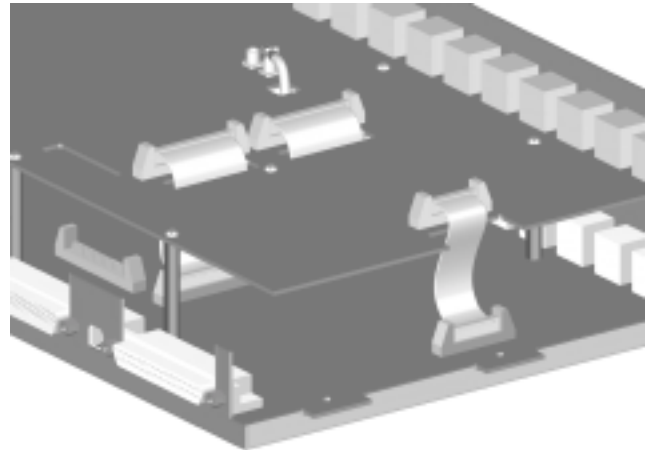

Expansion card, pillars and cables in situ

Extending the outer case

1. Fasten the two bright-metal stacker bars to the tops of the existing side panels using six 10mm M3 pan head screws. Do not use washers. The stacker bars are asymmetric and fit with the holes towards the inside, and the recesses upward.
2. Unscrew the four countersunk screws on the rear panel of the Signal outer case extension. Set the rear panel aside.
3. Place the rest of the Signal outer case on top of the 1401 outer case so that the front panels line up. Fasten the Signal case to the stacker bars with a 12mm M3 pan head screw in each corner. Do not use washers.
4. Slide the inner can assembly into the extended case until the earth spade terminal is close enough to reconnect to the earth wires. Be careful not to splay the case sides.
5. Slide the inner can home. Slide the black top panel into the top slot.
6. Replace the two rear panels, using the hex wrench provided. The assembly is now complete.

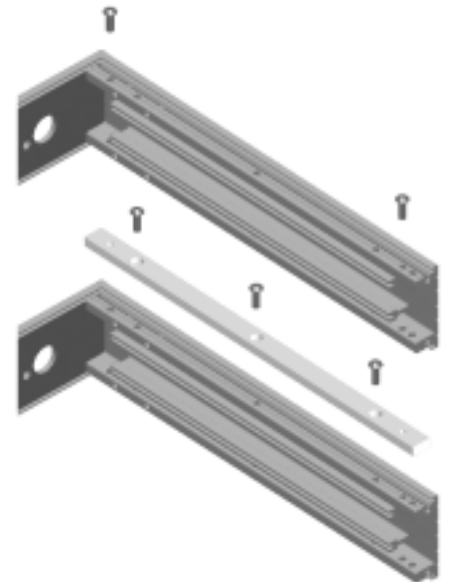

Stacker bar details

Self test

Connect only the power cable to the 1401 and switch on. At the end of its power-up self test, the 1401 red test LED should go out indicating that all is well and the unit is ready for use. If the red test LED flashes, this indicates an error. If this happens you should re-check all the steps for mistakes. Contact the CED service department if the problem persists.

Software configuration

Top cards contain self-identifying information in a small non-volatile memory chip. The 1401 monitor will detect the presence of the Signal top card as soon as the machine is powered up. To verify this, open the TRY1432 utility (typically, by selecting *Start, Run, Test1401, Try1432*) and select *1401info...* from the *File* menu. You will see a new line that identifies the top card type, and reports its issue and serial number. Application programs such as Signal and Spike2 accommodate the expanded hardware immediately; the new ADC input channels behave just like the original sixteen, and the DAC outputs like the original four.